

Topless MDT 162 H8

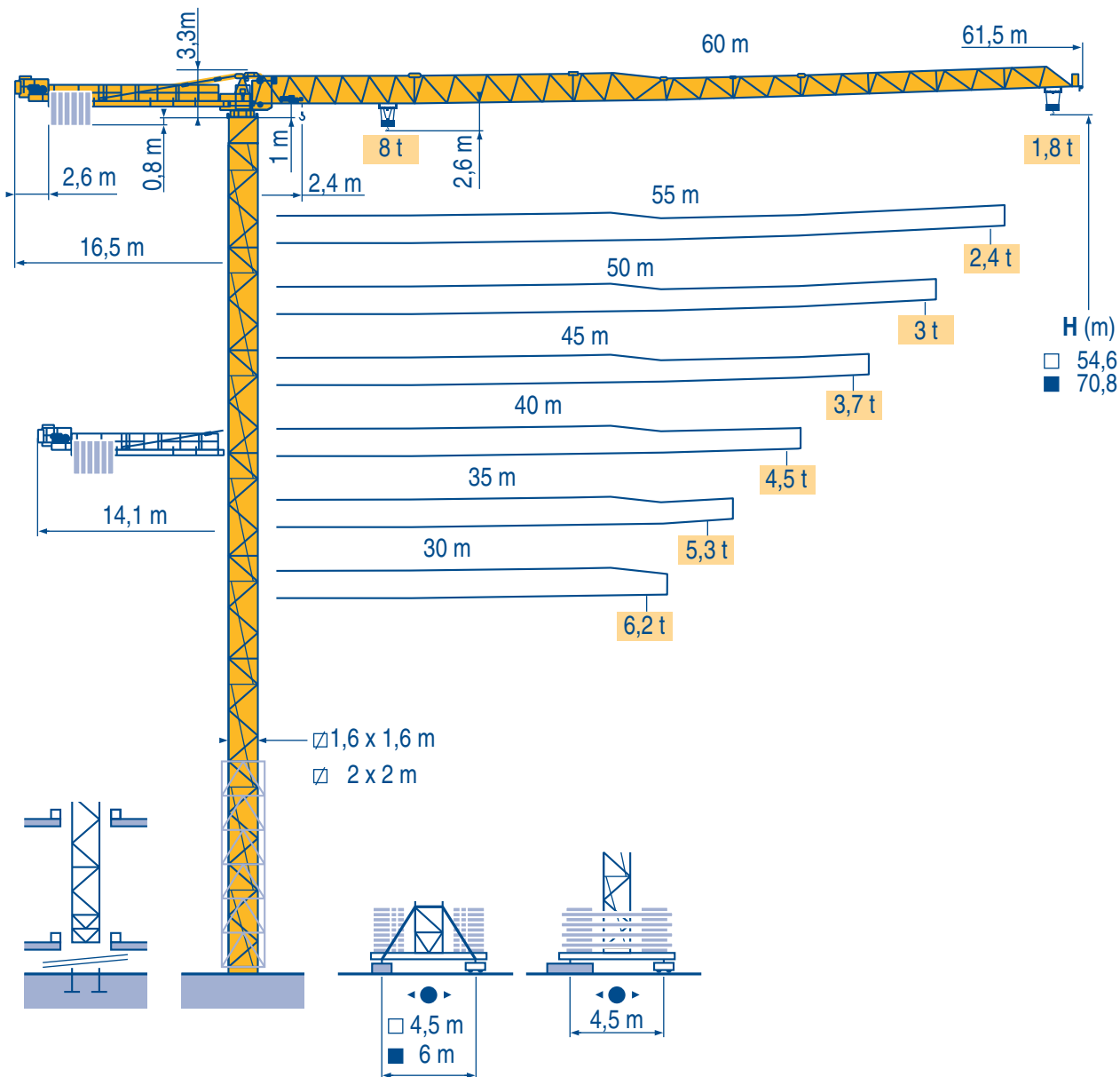

- Igo HD HDM
- HDT
- GTMR
- CITY CRANE
- TOPKIT MD MAXI MD
- MAXI TOPKIT
- Topless MDT
- MR

H (m)
 □ 54,6
 ■ 70,8

LQC 1

CE FEM 1.001-A3



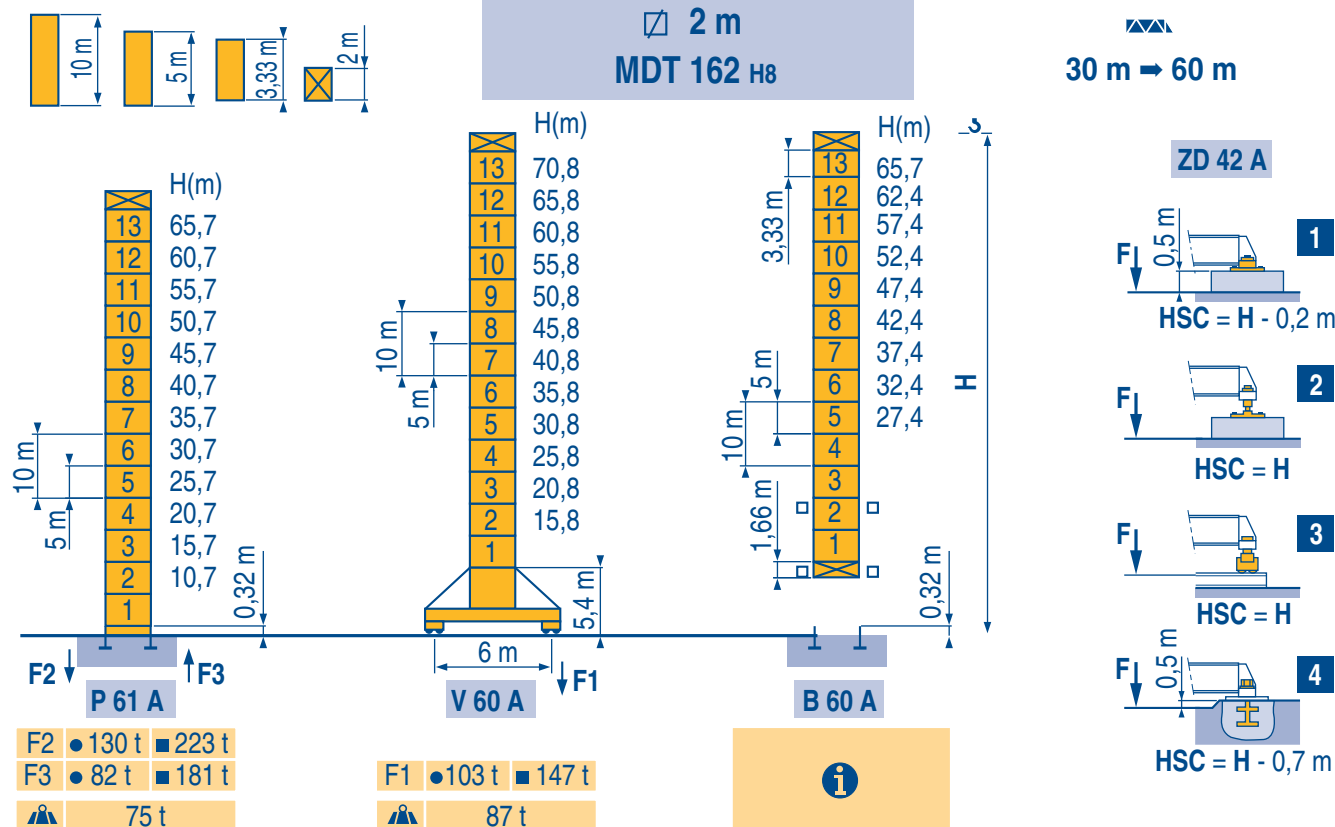
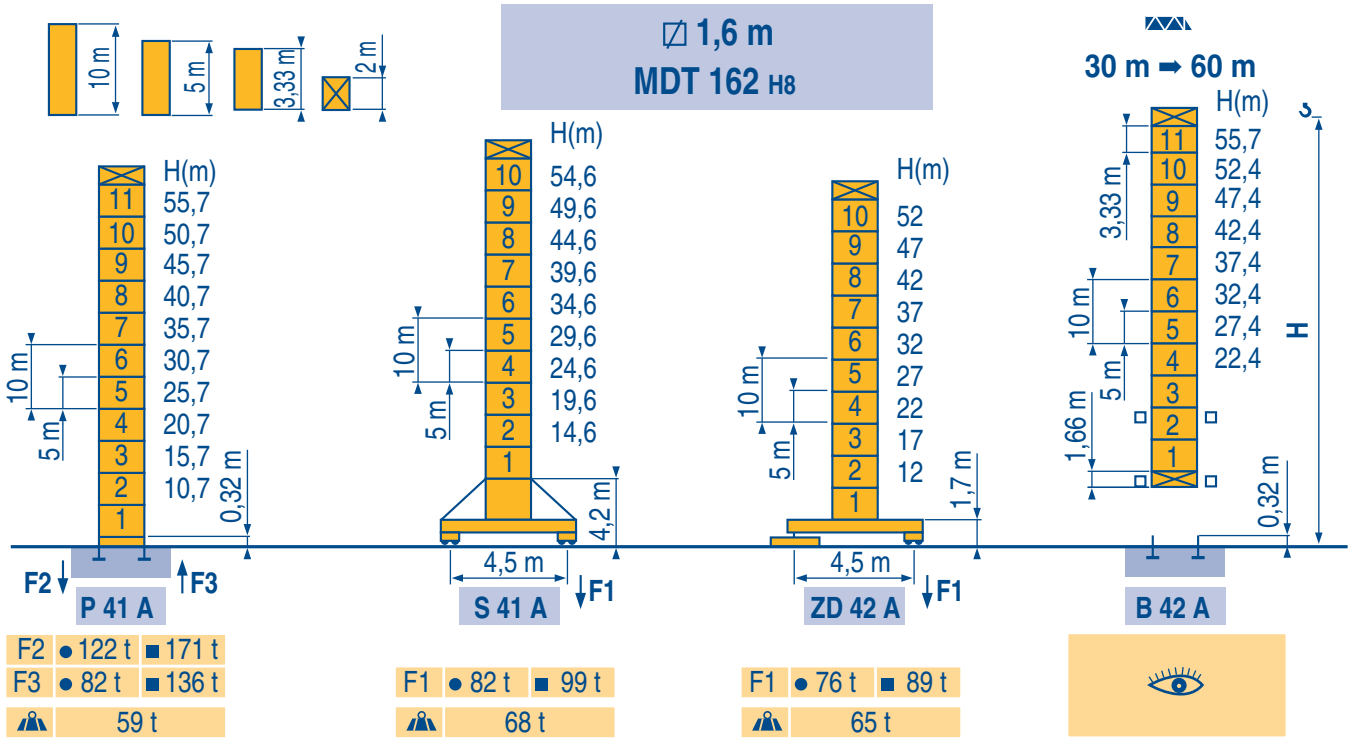

LQC 1

Icon	French	German	English	Spanish	Italian	Portuguese
	Voir télescopage sur dalles	Siehe Kletterkrane im Gebäude	See climbing crane	Veja grua trepadora	Consultare gru in cavedio	Ver telescopagem sobre lages
●	Réactions en service	Reaktionskräfte in Betrieb	Reactions in service	Reacciones en servicio	Reazioni in servizio	Reações em serviço
■	Réactions hors service	Reaktionskräfte außer Betrieb	Reactions out of service	Reacciones fuera de servicio	Reazioni fuori servizio	Reações fora de serviço
	A vide sans lest (ni train de transport) avec flèche et hauteur maximum.	Ohne Last, Ballast (und Transportachse), mit Maximalausleger und Maximalhöhe.	Without load, ballast (or transport axles), with maximum jib and maximum height.	Sin carga, sin lastre, (ni tren de transporte), flecha y altura máxima.	A vuoto, senza zavorra (ne assali di trasporto) con braccio massimo e altezza massima.	Sem carga (nem trem de transporte)-sem lastro com lança e altura máximas.
	Nous consulter	Auf Anfrage	Consult us	Consultarnos	Consultateci	Consultar-nos

Courbes de charges
Lastkurven



Load diagrams
Curvas de cargas



Curve di carico
Curva de cargas



60 m	2,4	▶	17,3	20	22,3	25	27	30	32	35	37	40	42	45	47	50	52	55	57	60 m
▲▲▲			8	6,8	6	5,3	4,8	4,3	4	3,6	3,3	3	2,9	2,6	2,5	2,3	2,2	2	1,9	1,8 t
55 m	2,4	▶	19,7	22	25	27	30	32	35	36	40	42	45	47	50	52	55 m			
▲▲▲			8	7,1	6,1	5,6	5	4,6	4,2	4	3,5	3,3	3,1	2,9	2,7	2,6	2,4 t			
50 m	2,4	▶	21,4	22	25	27	30	32	35	39	40	42	45	47	50 m					
▲▲▲			8	7,8	6,7	6,2	5,5	5,1	4,6	4	3,9	3,7	3,4	3,2	3 t					
45 m	2,4	▶	22,9	25	27	30	32	35	37	40	42	45 m								
▲▲▲			8	7,3	6,7	5,9	5,5	5	4,7	4,3	4	3,7 t								
40 m	2,4	▶	24	25	27	30	32	35	37	40 m										
▲▲▲			8	7,7	7	6,3	5,8	5,3	4,9	4,5 t										
35 m	2,4	▶	24,3	25	27	30	32	35 m												
▲▲▲			8	7,7	7,1	6,3	5,9	5,3 t												
30 m	2,4	▶	23,9	25	27	30 m														
▲▲▲			8	7,6	7	6,2 t														

LQC 1

Télescopage sur dalles
Kletterkrane im Gebäude



Climbing crane
Telescopage gruas trepadoras



Gru in cavedio
Telescopagem sobre lajes

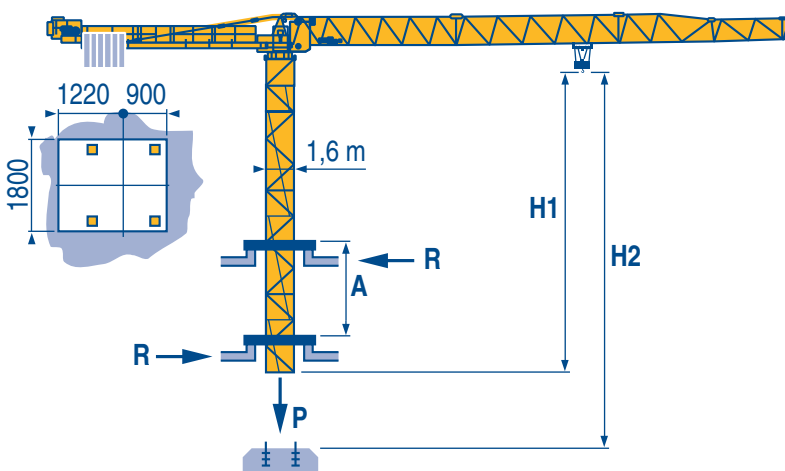

LQC 1

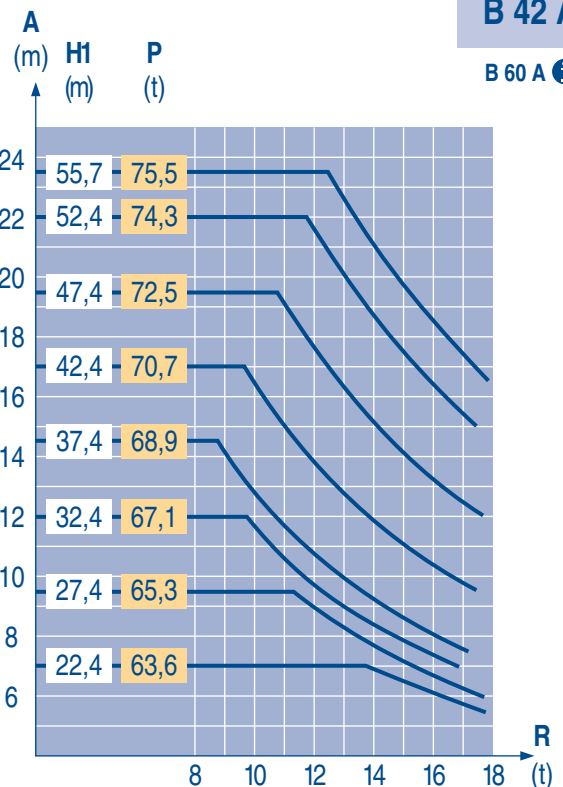

B 42 A

B 60 A ⓘ

A	Distance entre cadres	F	Abstand zwischen den Rahmen	D	Distance between collars	GB	Distancia entre marcos	E	Distanza fra i telai	I	Distância entre quadros	P
H1	Hauteur grue		Kranhöhe		Crane height		Altura grúa		Altezza gru		Altura da grua	
P	Poids de la grue (en service)		Krangewicht (in Betrieb)		Crane weight (in service)		Peso de la grúa (en servicio)		Peso della gru (in servizio)		Peso da grua (em serviço)	
R	Réaction horizontale		Horizontalkräfte		Horizontal reaction		Reaccion horizontal		Reazione orizzontale		Reacção horizontal	
ⓘ	Nous consulter		Auf Anfrage		Consult us		Consultarnos		Consultateci		Consultar-nos	

														ch - PS hp	kW				
▲ ▼	50 LVF 20 Optima	m/min	3,6 → 15 → 46 → 60 → 84 → 110							1,8 → 7,4 → 23 → 30 → 42 → 55					50	37	557 m >557		
	t	4	4	4	3	2	1	8	8	8	6	4	2						
◀ ▶	28 S 2,0 410	m/min	3,1/31			6,2/62				1,6/16		3,1/31			38	28	410 m >410		
	t	4			2				8		4								
◀ ▶	DV - 5.5	m/min	11 - 33 - 66														7,5	5,5	
	R - 8.8	tr/min U/min rpm	0 → 0,81														2 x 6	2 x 4,4	
	S 41 A RT 443 A1 2V	m/min	15 - 30														4 x 5	4 x 3,7	
R 10 m	ZD 42 A RT 324 A1 2V	m/min	12,5 - 25														2 x 7	2 x 5,2	
	V 60 A RT 544 A1 2V	m/min	13,5 - 27														4 x 7	4 x 5,2	
R 13 m																			
CEI 38		IEC 38		kVA															
400V (+6%-10%) 50 Hz				28 S 2,0 : 52 kVA 50 LVF 20 : 74 kVA							84/534 - 87/405								

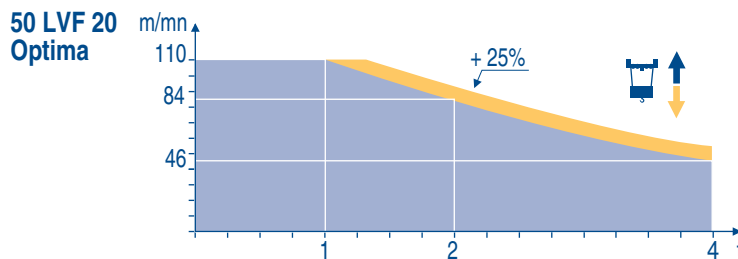

LQC 3

	Levage	Heben	Hoisting	Elevación	Sollevamento	Elevação
	Distribution	Katzfahren	Trolleying	Distribución	Ditribuzione	Distribuição
	Orientation	Schwenken	Slewing	Orientación	Rotazione	Rotação
	Translation	Kranfahren	Travelling	Traslación	Traslazione	Translação
	Conforme aux directives CEE 84/534 et 87/405 sur le niveau acoustique	Gemäss EWG-Richtlinien 84/534 und 87/405 für den Schall-Leistungspegel	In compliance with the EEC 84/534 and 87/405 Instructions on noise level	Conforme con las directivas CEE 84/534 y 87/405 sobre el nivel acústico	Conforme alle direttive CEE 84/534 e 87/405 sul livello acustico	Conforme as directivas CEE 84/534 e 87/405 sobre o nível acústico
	Nous consulter	Auf Anfrage	Consult us	Consultarnos	Consultateci	Consultar-nos

Document commercial non contractuel. Pour toute information technique se référer à la notice correspondante

Unverbindliches Vertriebsdokument. Für technische Informationen, siehe die entsprechenden Anweisungen.

This commercial document is not legally binding. For any technical information, please refer to the corresponding instructions.

Documento comercial no contractuel. Para cualquier información técnica, ver la noticia correspondiente.

Documento commerciale non vincolante, per tutte le informazioni tecniche fare riferimento al catalogo istruzioni

Documento comercial não contratual. Para qualquer informação técnica complementar consultar as respectivas instruções

POTAIN

18.Rue de Charbonnières, B.P. 173
F-69132 ECULLY Cedex
Tél. (33)04.72.18.20.20
Fax (33)04.72.18.20.00
http://www.potain.com
E-mail : mkt@potain.fr

Manitowoc Crane Group

Deutschland
POTAIN GmbH Tel : 06.1.05.70.40
Italia
POTAIN S.p.A. Tel : 0.331.49.33.11
Portugal
POTAIN Portugal Tel : 22.968.08.89
Singapore
MANITOWOC POTAIN PTE LTD Tel : 227.15.50

Copyright.Reproduction interdite © POTAIN 1998

Topless MDT 162 H8
Réf. 1998.45 LQC 6